



FIRST CLASS LED panel





🇬🇧 First Class LED panel

Easily adapted to suit your needs, this multi-functional machine is perfect for granita, iced coffee and tea, semi-frozen and frozen desserts, cocktails, sorbets, sangria, lemonade and much, much more.

Thanks to the patented 'total cold' system, the product is kept at a constant temperature, right down to the very last drop, guaranteeing optimal product quality and minimal wastage.

Plus, FC has been equipped of a led backlight panel to customize better the machine and ensure an appealing look.



Model / Modello	FC2 light panel	FC3 light panel
Height / Altezza	30.35 in 771 mm	23.86 in 771 mm
Width / Larghezza	16.93 in 430 mm	17.30 in 620 mm
Depth / Profondità	21.57 in 548 mm	18.23 in 548 mm
Weight / Peso	115 lb 52,5 kg	71.65 lb 64 kg
Capacity / Capacità	6.34 USgal 24 Lt	3.96 USgal 36Lt
Power / Potenza	1.34 hp 1000 W	0.72 hp 1200 W
Voltage_Frequency/ Voltaggio_Frequenza	220-240 V_ 50 Hz	220-240 V_ 50 Hz
	220 V_ 60 Hz	220 V_ 60 Hz
	115 V_ 60 Hz	115 V_ 60 Hz

Our company reserves the right to make changes without any notice.

WARRANTY / GARANZIA



colours:
■ ■ ■

Exclusive features

DOUBLE AUGERS
better mix



TOTAL COLD SYSTEM
no waste, quality until the last drop



NO RUBBER GASKET
no leaking, no periodical maintenance



ELECTRONIC SYSTEM
density control, auto-diagnostic, defrost



L'azienda si riserva il diritto di apportare, modifiche senza preavviso.

🇮🇹 First Class LED panel

Una macchina polifunzionale che si adatta alle tue esigenze perfetta per granita, caffè/tè ghiacciati o in crema fredda, cocktail, sorbetto, sangria, limonata e molto altro.

Grazie al sistema brevettato "total cold" il prodotto è tenuto a temperatura costante fino all'ultima goccia, senza sprechi e con qualità garantita.

L'aggiunta del pannello retroilluminato a led permette una completa personalizzazione e un look più fresco e accattivante!



ElmeCO srl

Via Circumvallazione Esterna, 12
80025 Casandrino, Napoli, Italy
Tel +39 081 5055724 Fax +39 081 5055726
info@elmeCO.com - www.elmeCO.com

ElmeCO USA

5200 77 Center Drive Suite 110
Charlotte NC 28217, U.S.A.
Tel: +1.877.435.6326 ext. 101 Fax: (704) 666-5141
info@elmeCO.com

First Class

*Respect
the environment •*

Consumes less •

Lasts longer •

PROPANE GAS R290

BRUSHLESS TECHNOLOGY

SELF-CLEANING-CONDENSER





UK First Class

Easily adapted to suit your needs, this multi-functional machine is perfect for granita, iced coffee and tea, semi-frozen and frozen desserts, cocktails, sorbets, sangria, lemonade and much, much more.

Thanks to the patented "total cold" system, the product is kept at a constant temperature, right down to the very last drop, guaranteeing optimal product quality and minimal wastage.

Completely seal-free, the machine is easy to disassemble and clean. An efficient, electronic core makes it simple and intuitive to use.

IT First Class

Una macchina polifunzionale, che si adatta alle tue esigenze. Perfetta per granita, caffè/tè ghiacciati o in crema fredda, cocktail, sorbetto, sangria, limonata e molto altro.

Grazie al sistema brevettato "total cold", il prodotto è tenuto a temperatura costante fino all'ultima goccia, senza sprechi e con qualità garantita.

Facile da disassemblare e pulire, non ha guarnizioni. Un efficace cuore elettronico rende semplice il suo utilizzo.

230Vac/50Hz

FC2 Standard

FC2 GREEN

Preparation time

T.preparaz. prodotto

min

min

Energy consumption

Consumi energetici

kwh

kwh

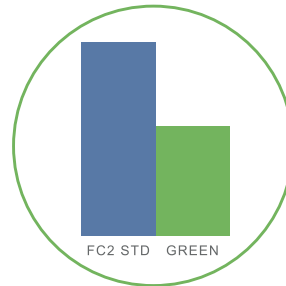

FC2 STD GREEN

Exclusive features

Double augers
Better mix
Doppie cocclee
Mix migliore



No rubber gasket, no leaking,
no periodical maintenance
Nessuna guarnizione in plastica, nessuna perdita, nessuna manutenzione periodica



Total cold system
Sistema a freddo totale



Electronic system, density control,
Auto diagnostic
Sistema elettronico, controllo della densità, autodiagnosi



	Peso Weight		Capacità Capacity		Potenza Power		Vtaggio Voltage
	kg.	lb.	lt.	gal.	W	Hp	
FC1	31	68.30	12	3.17	500	0.67	220-240/50 220/60 115/60
FC2	52	114.60	24	6.34	930	1.24	220-240/50 220/60 115/60
FC3	64	141.10	36	9.51	1150	1.54	220-240/50 220/60 115/60



WARRANTY / GARANZIA

Standard:

- 5 years - compressor
- 3 years - electronic board
- 2 years - parts(excepted plastic items)
- 1 year - labor

Extend your warranty:

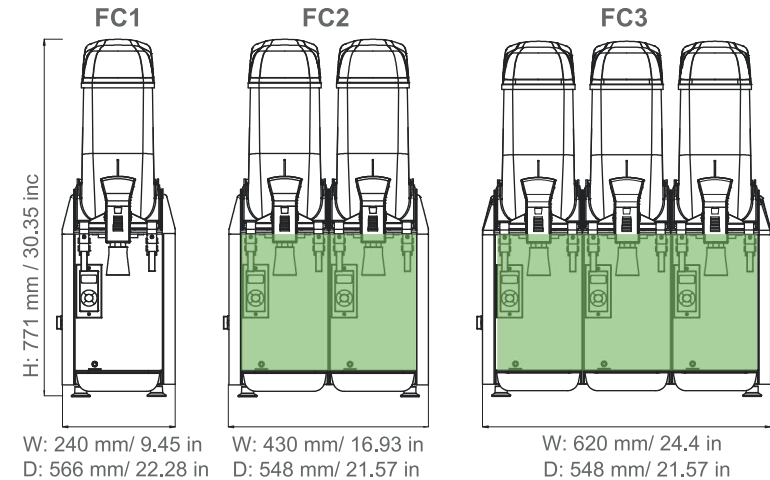

Colours:

Front led panel available. Disponibilità pannello LED frontale



Elmeco srl

via Circumvallazione Esterna, 12
80025 Casandrino, Napoli, Italy
Tel +39 081 5055724 - Fax +39 081 5055726

Elmeco LLC USA

652 Griffith Road Suite E
Charlotte NC 28217, USA
Tel: +1-877-435-6326

info@elmeco.com



BLarge

think wider •
think positive •



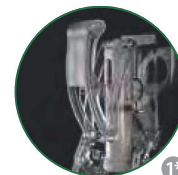

UK BLarge

BLarge is a young but highly proficient machine, resulting from Elmecco's many years of experience in the field.

Highly reliable and compact, it still maintains all the necessary technical features of Elmecco machines, and also comes with a portion-control dispensing system.

Perfect for granita, soft drinks, semi-frozen and frozen desserts, iced coffee and tea, cocktails, sorbet, frozen yogurt, sangria, lemonade and much, much more... Discover new recipes, Invent new flavours!

IT BLarge

BLarge è una macchina giovane ma esperta che deriva dall'esperienza che la Elmecco ha raggiunto fino ad ora.

Mantiene ogni caratteristica tecnica e di affidabilità, occupa poco spazio e può avere un sistema di erogazione a controllo porzioni.

Perfetta per granite, bibite e creme fredde, caffè/tè, cocktail, sorbetto, yogurt freddo, sangria(!), limonata e molto ancora.. Scopri nuove ricette inventa nuovi gusti!

230Vac/50Hz	BL Standard	BL Green
Preparation time T.preparaz. prodotto	min	min
Energy consumption Consumi energetici	kwh	kwh



1 Patented dispensing system
Sistema di erogazione brevettato

2 Removable external condenser air-filter
Filtro esterno rimovibile

Exclusive features

Self service dispensing system
Sistema di erogazione self service



No rubber gasket, no leaking,
no periodical maintenance
Nessuna guarnizione in plastica, nessuna perdita, nessuna manutenzione periodica



Total cold system
Sistema a freddo totale



Electronic system, density control,
Auto diagnostic
Sistema elettronico, controllo della densità, autodiagnosi



	Peso Weight		Capacità Capacity		Potenza Power		Voltage Voltage
	kg.	lb.	lt.	gal.	W	Hp	
BL1	22.2	49	7,5	1.98	5	60	220-240/50 220/60 115/60 100/50-60
BL2	32.5	71.65	15	3.96	6	0.75	220-240/50 220/60 115/60 100/50-60



WARRANTY / GARANZIA

Standard:

- 5 years - compressor
- 3 years - electronic board
- 2 years - parts(excepted plastic items)
- 1 year - labor

Extend your warranty:

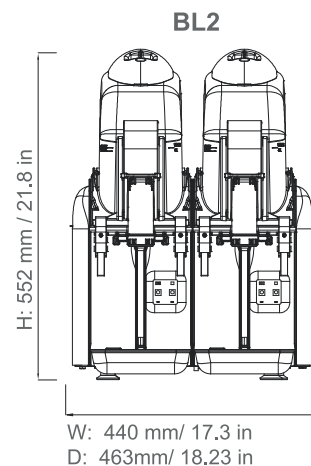
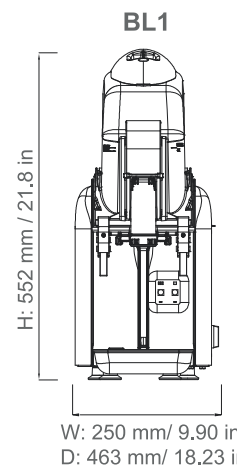

Credit Management System BSmart



Elmecco srl

via Circumvallazione Esterna, 12
80025 Casandrino, Napoli, Italy
Tel +39 081 5055724 - Fax +39 081 5055726

Elmecco LLC USA

652 Griffith Road Suite E
Charlotte NC 28217, USA
Tel: +1-877-435-6326

info@elmecco.com





Big Biz

Big Business •
Compact size •





Big Biz

Big Biz is a multi-functional machine that is easy to use and clean. Extremely flexible and space-saving, Big Biz guarantees big profits, with the added bonus of low investment and maintenance costs.

BB produces small quantities of granita, making it easy to adapt the product to suit your clients ever-changing tastes.

Perfect for Italian-style granita, iced coffee and tea, soft drinks, desserts, sorbets, ice-cold cocktails, lemonade and much, much more... Discover new recipes, invent new flavours!

Big Biz

Big Biz è una macchina polifunzionale e facile da usare e ripulire, offre grande flessibilità e occupa poco spazio.

BB garantisce un grande profitto con un piccolo investimento e praticamente inesistenti spese di manutenzione. BB produce piccole quantità di granita adatte ad assecondare frequenti cambi di gusto. Perfetto per granita, crema caffè e tè, o bibite e creme fredde, sorbetti, cocktail ghiacciati, limonata e molto altro...

Scopri nuove ricette, inventa nuovi gusti!

230Vac/50Hz

BB Standard

BB Green

Preparation time

T.preparaz. prodotto

min

min

Energy consumption

Consumi energetici

kwh

kwh



BB STD GREEN

	Peso Weight		Capacità Capacity		Potenza Power		Vtaggio Voltage
	kg.	lb.	lt.	gal.	W	Hp	
BB1	22	48.50	6	1.58	450	0.60	220-240/50 220/60 115/60 100/50-60
BB2	32	70.50	12	3.17	560	0.75	220-240/50 220/60 115/60 100/50-60



WARRANTY / GARANZIA

Standard:

- 5 years - compressor
- 3 years - electronic board
- 2 years - parts(excepted plastic items)
- 1 year - labor

Extend your warranty:



Exclusive features

Compact & Easy
Compatto e Semplice



No rubber gasket, no leaking,
no periodical maintenance
Nessuna guarnizione in plastica, nessuna perdita, nessuna manutenzione periodica



NO SEAL

Total cold system
Sistema a freddo totale



Electronic system, density control,
Auto diagnostic
Sistema elettronico, controllo della densità, autodiagnosi

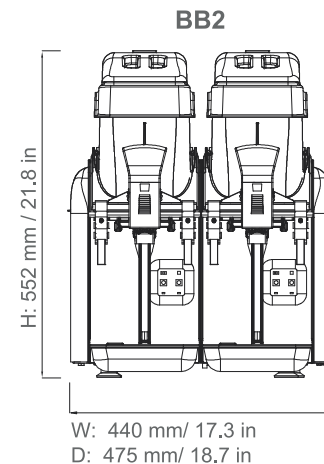
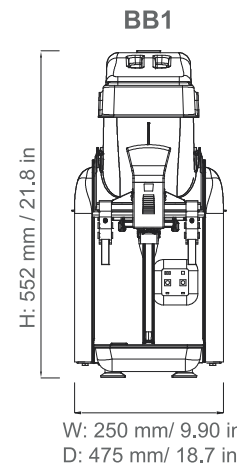

Colours:



Elmeco srl

via Circumvallazione Esterna, 12
80025 Casandrino, Napoli, Italy
Tel +39 081 5055724 - Fax +39 081 5055726

Elmeco LLC USA

652 Griffith Road Suite E
Charlotte NC 28217, USA
Tel: +1-877-435-6326

info@elmeco.com





Quickcream

*A soft soul in a
broad - shouldered
machine*



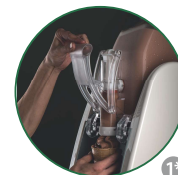
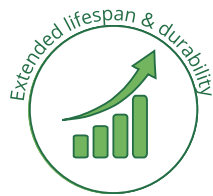

UK Quickream

This machine has been specifically designed for making and dispensing semi-frozen and frozen ice-cream, frozen yogurt, frappes and smoothies...

Quick and easy to disassemble and clean, Quickream guarantees maximum hygiene for milk-based products.

Thanks to the easy-to-use electronic functions and a patented dispensing system, the QK serves electronically measured portions of approximately 70 grammes each.

With it's soft, appealing lines and a wide range of customi-sable shells, the QK will furnish your bar or restaurant in style.

IT Quickream

Ideato per la produzione ed erogazione di un gelato soffice e cremoso, yogurt freddo, frappè, frullati.

Facile e veloce da smontare e pulire, Quickream garantisce la massima igiene con prodotti a base di latte. Grazie all'elettronica di facile utilizzo e il brevettato sistema di erogazione, Qk eroga porzioni di circa 70 grammi ciascuna, conteggiate elettronicamente.

Dal design morbido e avvolgente, con ampie scocche personalizzabili, QK arreda il tuo locale.

230Vac/50Hz	QK Standard	QK Green
Preparation time T.preparaz. prodotto	min	min
Energy consumption Consumi energetici	kwh	kwh

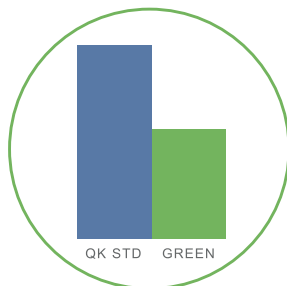

1 Patented dispensing system
Sistema di erogazione brevettato

2 Removable external condenser air-filter
Filtro esterno rimovibile

Exclusive features

SELF SERVICE DISPENSING SYSTEM

TOTAL COLD SYSTEM
no waste, quality until the last drop

BRUSHLESS
reduces energy consumption and noises

NO RUBBER GASKET
no leaking, no periodical maintenance

ELECTRONIC SYSTEM
density control, auto-diagnostic, defrost



QK1	Peso Weight		Capacità Capacity		Potenza Power		Voltaggio Voltage
	kg.	lb.	lt.	gal.	W	Hp	V/Hz
	27	59.5	4	1.05	410	0.55	220-230/50 220/60 115/60 100/150-60



WARRANTY / GARANZIA

Standard:

- 5 years - compressor
- 3 years - electronic board
- 2 years - parts(excepted plastic items)
- 1 year - labor

Extend your warranty:

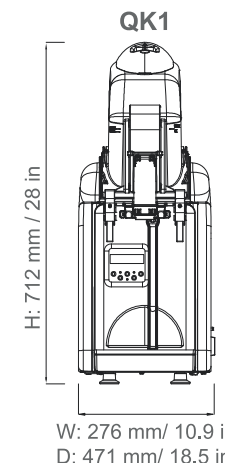

Colours: Credit Management System QSmart



Elmecco srl

via Circumvallazione Esterna, 12
80025 Casandrino, Napoli, Italy
Tel +39 081 5055724 - Fax +39 081 5055726

Elmecco LLC USA

652 Griffith Road Suite E
Charlotte NC 28217, USA
Tel: +1-877-435-6326

info@elmecco.com





ELMECCO

FCM Autofill System



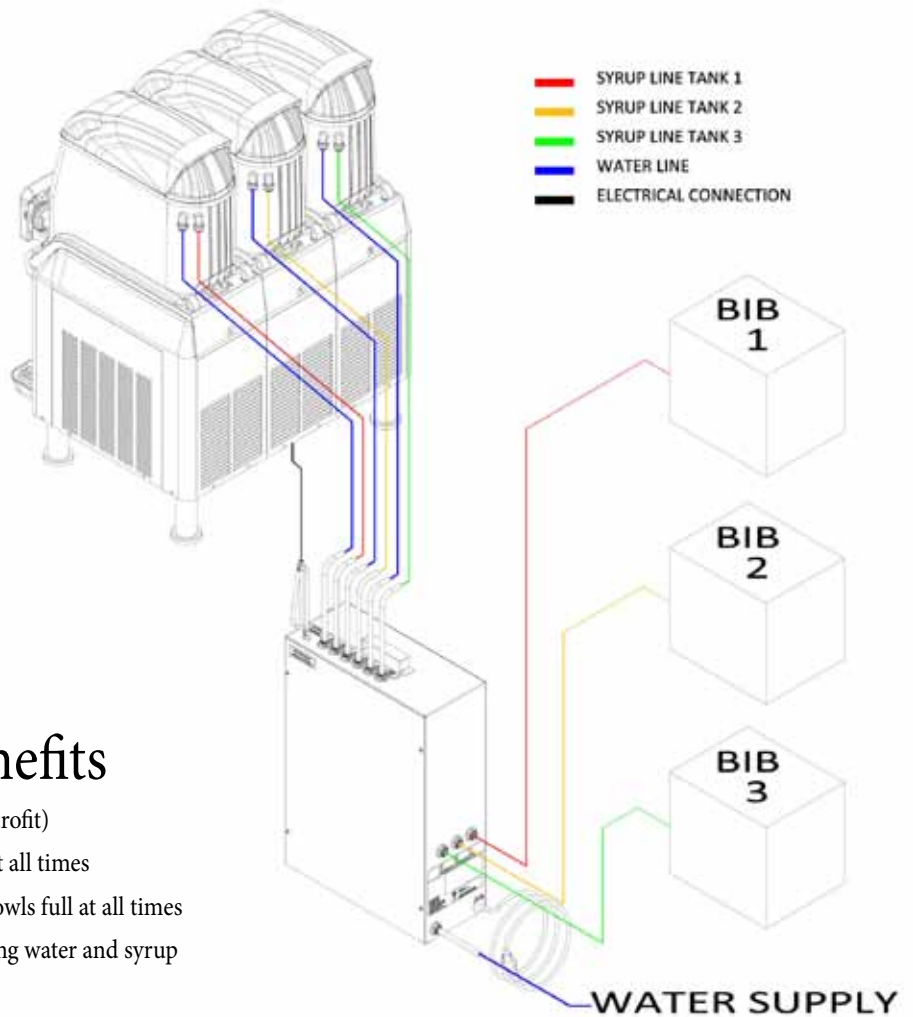

FCM Autofill System benefits

- ◆ Easy to set up on the existing (non-autofill) machine (retrofit)
- ◆ Maximizes output production by keeping machine full at all times
- ◆ Reinforces merchandizing effect by keeping machine's bowls full at all times
- ◆ Eliminates potential human errors in process of premixing water and syrup
- ◆ No additional maintenance required

MODEL	FCM-2 Autofill	FCM-3 Autofill
HEIGHT	11" / 29 cm	11" / 29 cm
WIDTH	20" / 52 cm	20" / 52 cm
DEPTH	24" / 60 cm	24" / 60 cm
WEIGHT	40 lbs / 18 kg	42 lbs / 19 kg

FCM Autofill System features

- ◆ Available for Elmeco granita freezers models FCM- 2 & FCM-3
- ◆ Equipped with SHURFlo Brix Pumps at 3:1, 4:1 or 5:1 ratios
- ◆ Bag-n-box (BIB) autofill system refills product at rate of 2-3oz [60-90cc] per sec. (varies for different types of concentrate)
- ◆ Plumbing: operating water pressures 50 PSI. [3.4 bar] MIN. / 125 PSI. [8.3 bar] MAX. ACCURACY: ± 3% of available ratio
- ◆ Contains pumps, tubes and solenoids in one, easy-to-handle box
- ◆ Power cord included, must be plugged in individually from the machine (110V/60Hz)
- ◆ Equipped with automatic cleaning and sanitizing valves
- ◆ Contains overflows protection mechanism
- ◆ Equipped with automatic alarm when syrup BIB empty or insufficient water pressure provided

Distributed by:



Elmeco srl
 12 Circumvallazione Esterna Street
 Casandrino NA 80025, Italy
 Tel. +39 081/5055724
 Fax +39 081/5055726

U.S. Subsidiary
 Tel: 1-877-435-6326
 Fax: 1-504-613-4603

www.elmeco.com | info@elmeco.com

Equipment warranty:

Parts/Compressor – 5 years

Parts/Electronics – 3 years

Parts – 2 years

Labor – 1 year

